

Uwagi:  
 1. Ostre krawędzie stępić.  
 2. Minimum After Forming (MAF) - 7 mm.

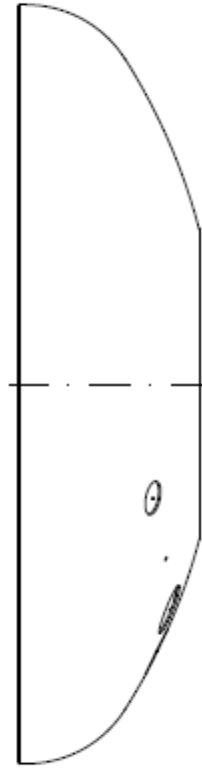

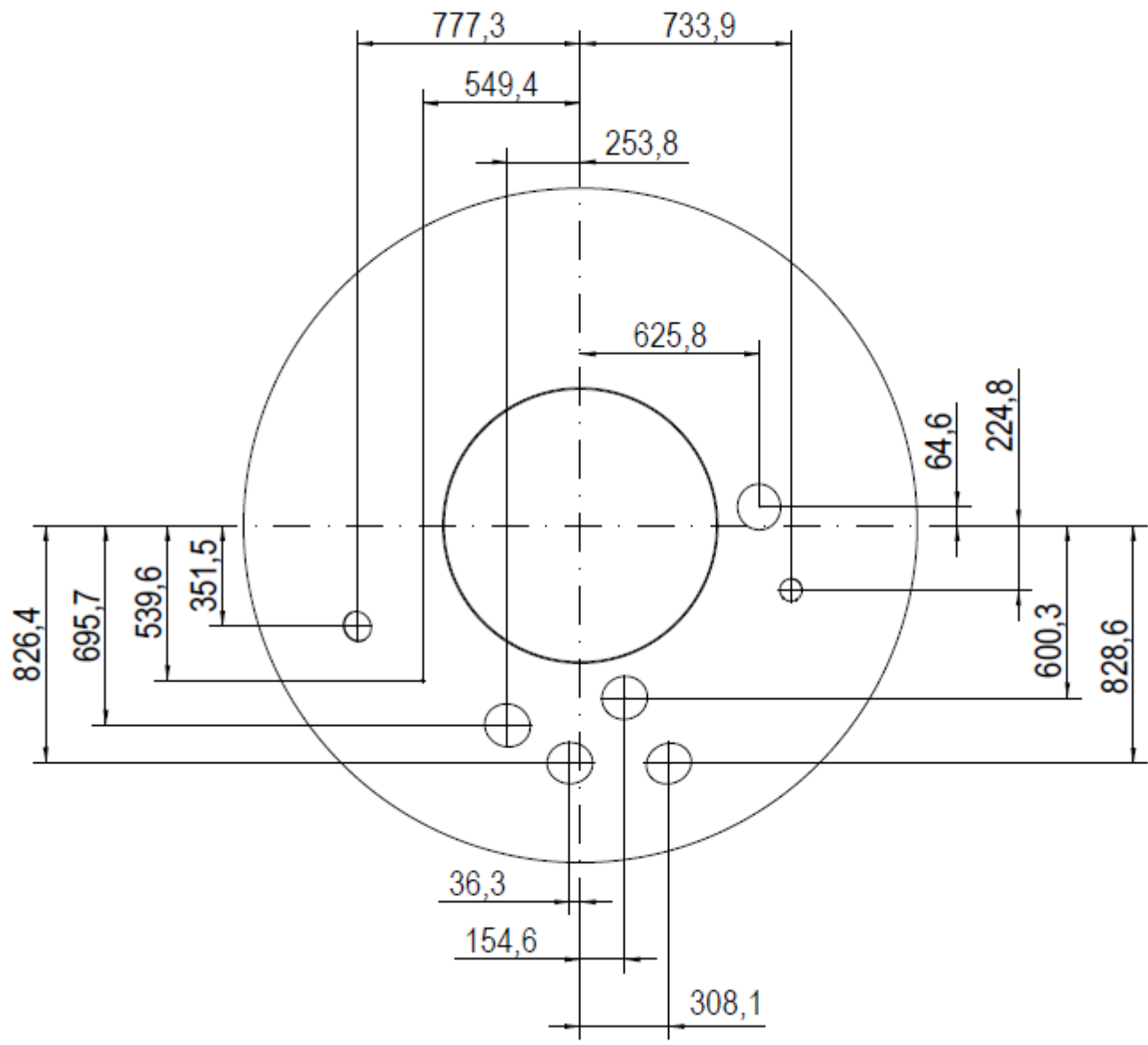

SZCZEGÓL B (1:2)

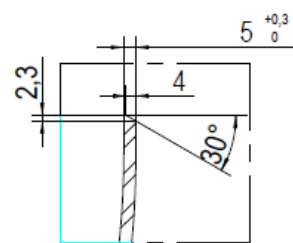
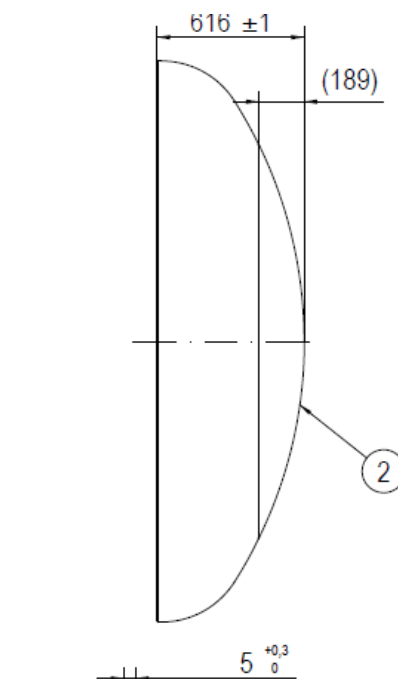
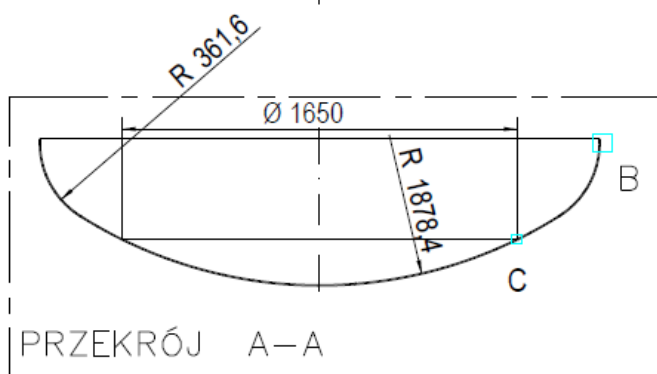
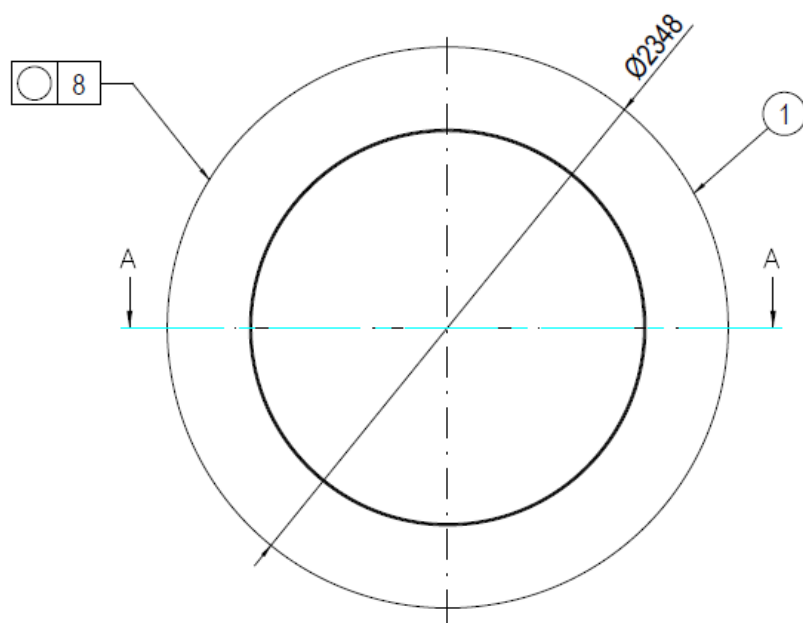
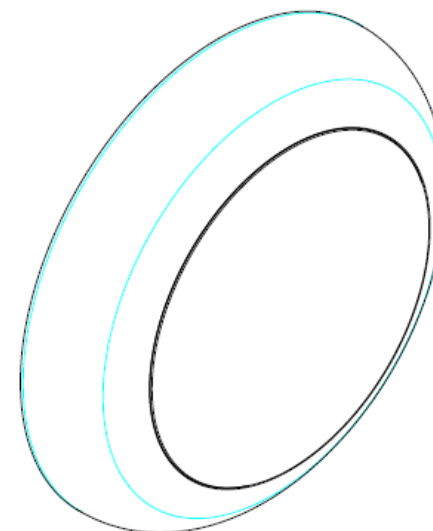

Uwagi:

1. Ostre krawędzie stępić.
2. Minimum After Forming (MAF) - 5 mm.
3. Otwór dennicy oraz montażową jej część fazować na całym obwodzie 5x30°.
4. Spoinę zamykającą dennicę wykonać zgodnie ze szczegółem V rys. 20-03-000-05.

2	1	Montażowa część dennicy	82,0 kg	0355J2 z bederlem -40°C/ PIV-EN 10025-2 / DIN28013
1	1	Dennica zewnętrzna strona przesuwna	145,0 kg	0355J2 z bederlem -40°C/ PIV-EN 10025-2 / DIN28013

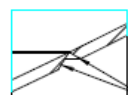

UWAGA 3

SZCZEGÓL C (1:2)

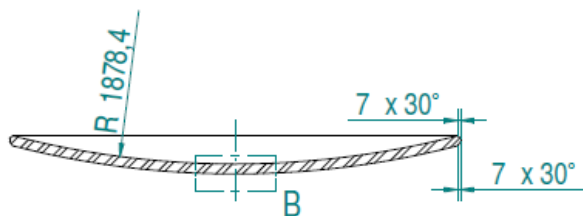
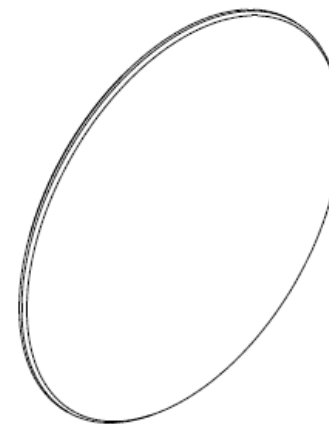
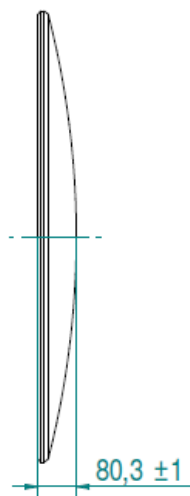
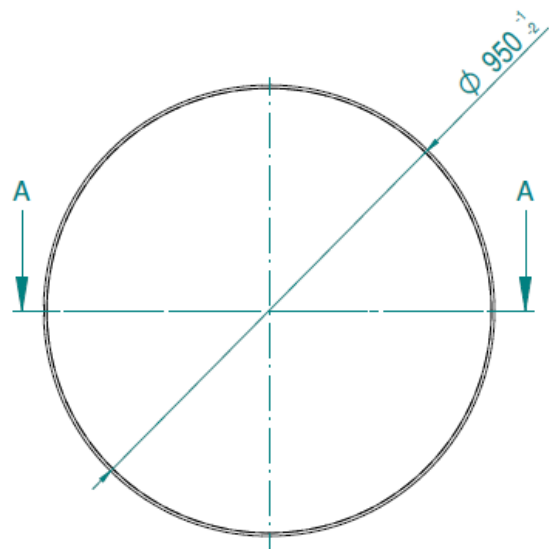

PRZEKRÓJ A-A

1	1	Flanża	118,4 kg	S355J2 z badaniem -40°C/ PN-EN 10025-2/ DIN 28013
---	---	--------	----------	---------------------------------------------------

Uwagi:

1. Flanża wykonana z geometrii dennicy.
2. Ostre krawędzie stępic.
3. Minimum After Forming (MAF) - 20 mm.
4. Fazować obustronnie 7x30°.

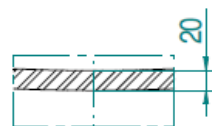

SZCZEGÓŁ B (1:5)

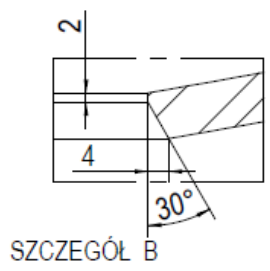
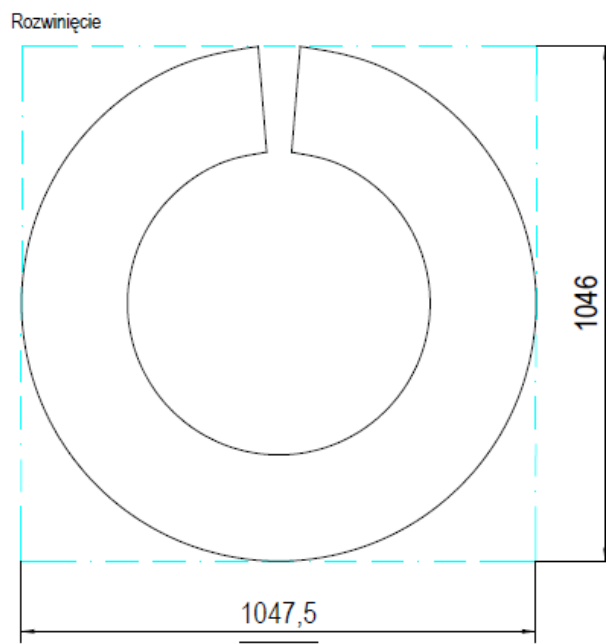
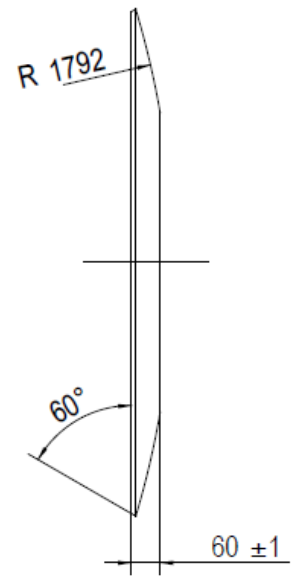
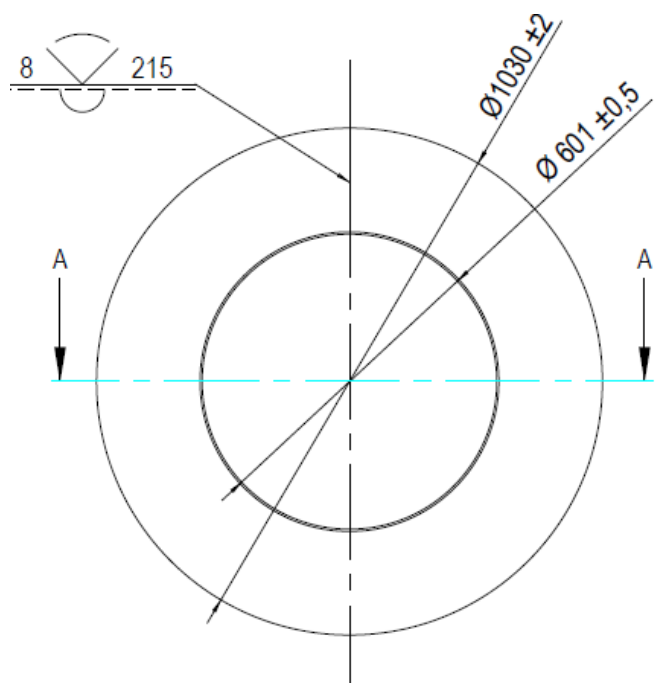

1	1	Blacha MAF - 8 mm	42,6 kg	1.4301 / PN-EN 10028-7 / DIN28013	3,1
---	---	-------------------	---------	-----------------------------------	-----

Uwagi:  
1. Ostre krawędzie stępić.